

排齒詳圖
Drawing of Serration

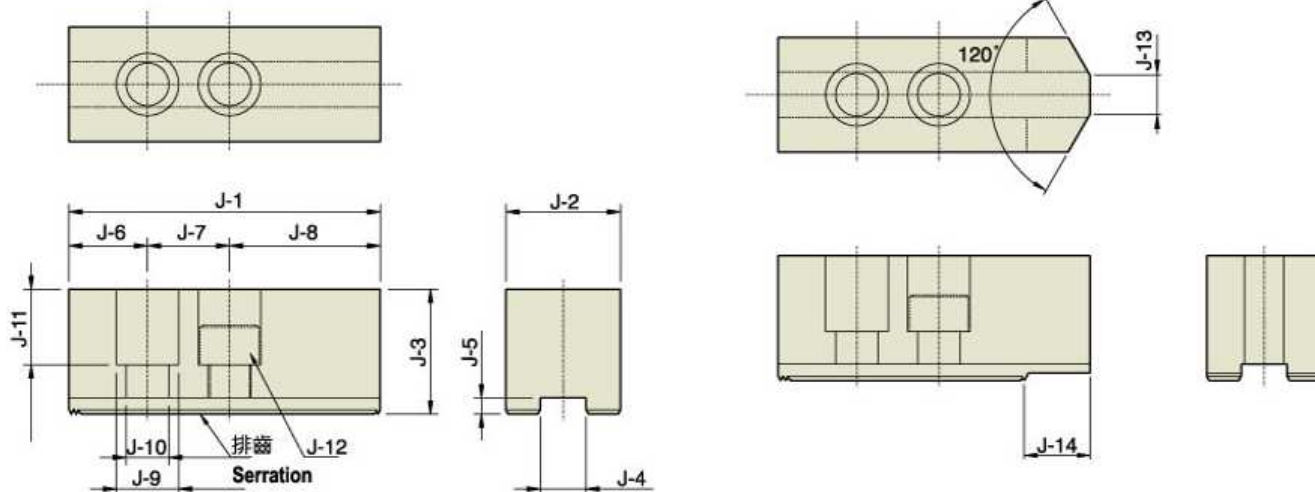

■ 尺寸表 DIMENSIONS

型 式 Model	J-1	J-2	J-3	J-4	J-5	J-6	J-7	J-8	J-9	J-10	J-11	J-12	J-13	J-14	排齒節距 Serration
HC04	49.5	23	23	10	4	10	14	25.5	13.5	8.5	14	M8	4		1.5X60°
HC05	54	23	25	10	4	12	14	28	13.5	8.5	16	M8	5		1.5X60°
HC06	66	32	28	12	5	12	20	34	17	11	16	M10	5	12	1.5X60°
HC08	95	35	38	14	5	24	25	46	19	13	23	M12	12	20	1.5X60°
HC10	110	40	42	16	6	30	30	50	19	13	27	M12	18	20	1.5X60°
HC12	130	50	50	21	6	39	30	60	25	17	30	M16	18	30	1.5X60°
HC12-1	130	50	50	18	6	39	30	60	23	15	30	M14	18	30	1.5X60°
HC15	165	62	62	22	8	37	43	85	32	21	38	M20			1.5X60°
HC15-1	135	50	60	25.5	5	26	43	66	32	21	39	M20	-	-	1.5X60°
HC-21	185	62	70	25	9	40	60	85	32	21	46	M20	-	-	3.0×60°