

**2-JAW WEDGE TYPE NON THROUGH-HOLE
POWER CHUCK (WITHOUT ADAPTOR)**

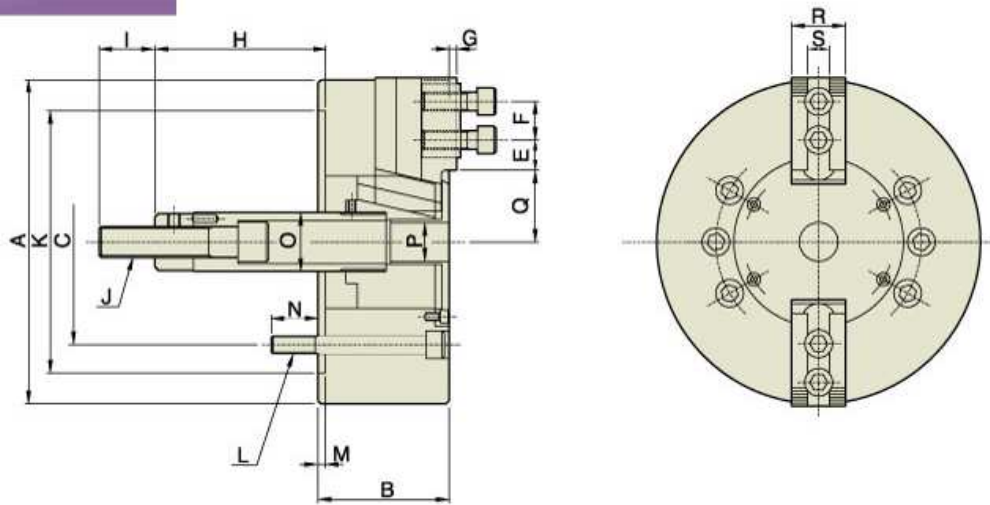

規格 SPECIFICATIONS

尺寸 Dim	型式 Model	VT-206	VT-208	VT-210	VT-212	VT-215
爪行程 Jaw Stroke (Dia) (mm)		8.5	8.8	8.8	10.5	16
柱塞行程 Plunger Stroke (mm)		20	21	25	30	35
夾持範圍 Gripping Range	最大 Max (mm)	165	210	254	304	381
	最小 Min (mm)	18	22	24	25	68
最大推力 Max. Pull Force	KN(kgf)	12(1224)	16.5(1683)	19.5(1988)	27.5(2804)	55(5609)
最大夾持力 Max. Gripping Force	KN (kgf)	34(3469)	50(5099)	72(7242)	104(10505)	166(16827)
最高轉速 Max. Speed (r.p.m)		5100	4650	3810	3200	2800
重量 Weight (kg)		12	22	33	57.3	96
慣性矩 Moment of Inertia (kg.m ²)		0.04	0.13	0.29	0.7	1.7
適合油壓缸 Matching Cylinder		MH100	MH125	MH125	MH150	MH200
適合之軟爪 Maching Soft Jaw		HC06	HC08	HC10	HC12-1	HC15-1
適合之硬爪 Matching Hard Jaw		HJ06	HJ08	HJ10	HJ12-1	HJ15-1

尺寸表 DIMENSIONS

尺寸 Dim	型式 Model	VT-206	VT-208	VT-210	VT-212	VT-215
A		165	210	254	304	381
B		74	85	89	106	114
C		104.78	133.35	171.45	171.45	235
E	Max.	18	22.5	37.5	47	50.25
	Min.	7.5	9	10.5	11	23.25
F		20	25	30	30	43
G		4	5	5	5	2
H	Max.	106.5	132	163	168	104
	Min.	86.5	111	138	138	69
I		36	36	36	36	55
J		M16x2.0	M20x2.5	M20x2.5	M20x2.5	M30x3.5
K(H6)		140	170	220	220	300
L		6-M10	6-M12	6-M16	6-M16	6-M20
M		5	5	5	6	6
N		14	20	18	22	29
O		34	38	45	50	60
P		21	25	34	34	-
Q	Max.	37.8	46.3	51.1	61	77.5
	Min.	33.5	41.9	46.7	55.75	69.5
R		31	35	40	50	50
S		12	14	16	18	25.5